

# Multiway ball valve for manifold mounting Steel

## MPKH4

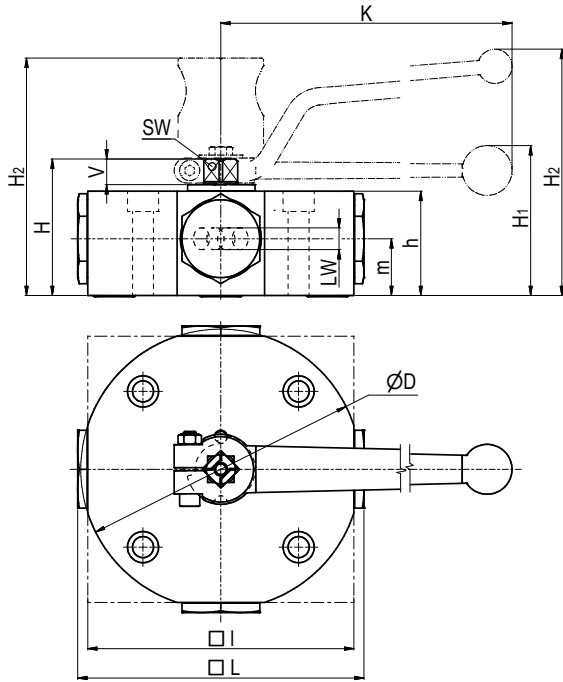

### AVAILABLE SIZES

DN6 - DN40 (1/4" to 1 1/2")

### ACCESSORIES ON REQUEST

- Locking devices on request
- Actuators page 220 - 221
- Position switches on request

### MATERIAL CODE DESCRIPTION

Materials	112A	112A	1128	1128
Body	Steel	Steel	Steel	Steel
Trunnion ball	Steel	Steel	Steel	Steel
Ball seats	POM	POM	POM	POM
O-rings	NBR	NBR	FPM	FPM
Tmin /Tmax	-20°C / 100°C	-20°C / 100°C	-20°C / 100°C	-20°C / 100°C
Porting pattern	T=SB13	X=SB14	T=SB13	X=SB14

### GENERAL DIMENSIONS

Type	LW <sub>T</sub>	LW <sub>x</sub>	I	L	D	H	h	m	V	SW	K	H <sub>1</sub>	H <sub>2</sub>	Lever	Weight [Kg]
MPKH4-DN6	5	4	90	102	-	58	40	22	13	12	160	-	101	Al	2,40
MPKH4-DN10	8	7	100	111	-	68	50	27	14	14	200	72	-	Zn	3,70
MPKH4-DN13	13	10	140	154	150	78	60	31	14	14	200	82	-	Zn	7,50
MPKH4-DN20	18	14	171	184	180	88	67	36,5	16,5	17	320	97	-	Al	12,00
MPKH4-DN25	23	16	205	225	215	96	75	40,5	16,5	17	320	106	-	Al	19,00
MPKH4-DN32	32	25	260	288	275	147	115	62	26	22	600	-	193	St <sup>(1)</sup>	56,60
MPKH4-DN40	38	32	301	332	315	156	125	65	25	22	600	-	204	St <sup>(1)</sup>	60,70

<sup>(1)</sup> Lever must be fixed centrally during operation. In case of vibration the handle may otherwise operate the valve by itself.

### CONNECTION

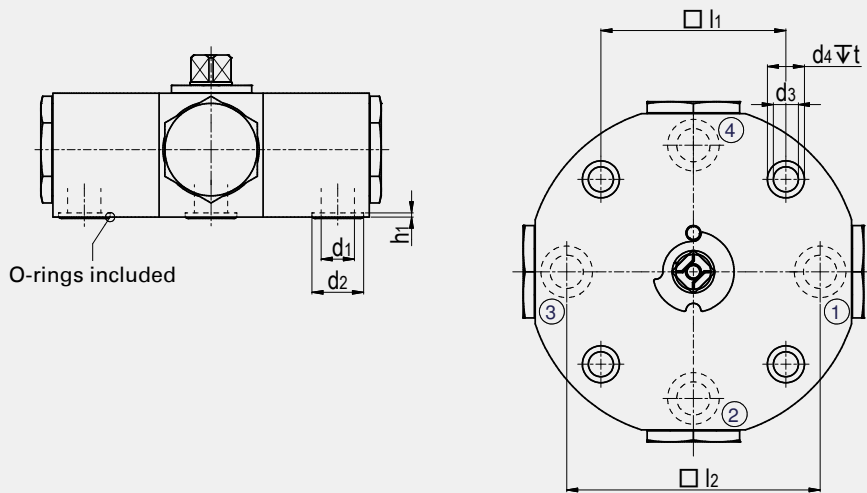

### CONNECTION DIMENSIONS

Type	l <sub>1</sub>	l <sub>2</sub>	d <sub>1</sub>	d <sub>2</sub>	h <sub>1</sub>	O-ring	d <sub>3</sub>	d <sub>4</sub>	t	Dimension of screws (min)	Torque of screws in Nm	ORDER CODE PER MATERIAL COMBINATION				
												PN [bar]	112A T=SB13	112A X=SB14	1128 T=SB13	1128 X=SB14
MPKH4-DN6	70	68,6	6	14	2	9x2,5	11	18	11	4 x M10 - 10.9	60	400	30629	29141	38475	35624
MPKH4-DN10	80	81	8	14,3	2	9,5x2,5	11	18	11	4 x M10 - 10.9	60	315	38467	29140	38476	19172
MPKH4-DN13	90	115,4	13	19,8	2	15x2,5	13,5	20	13	4 x M12 - 10.9	100	315	22200	26983	38477	38482
MPKH4-DN20	100	137	18	27,9	2,3	22x3	13,5	20	13	4 x M12 - 12.9	110	250	38468	38471	38478	31163
MPKH4-DN25	115	162	23	31,9	2,3	26x3	18	26	18	4 x M16 - 12.9	300	250	11603	38472	38479	38483
MPKH4-DN32	148,5	180	32	39,9	2,3	34x3	22	33	21,5	4 x M20 - 12.9	600	250	38469	38473	38480	38484
MPKH4-DN40	155,5	206	38	55,9	2,3	50x3	26	40	25,5	4 x M24 - 12.9	1000	250	38470	38474	38481	38485

Due to material availability the material code of the steel valves may vary from 112A (or 1128). DN13-40=812A (or 8128). Material suitability for the application does not differ from 112A (or 1128).

### PORTING PATTERNS

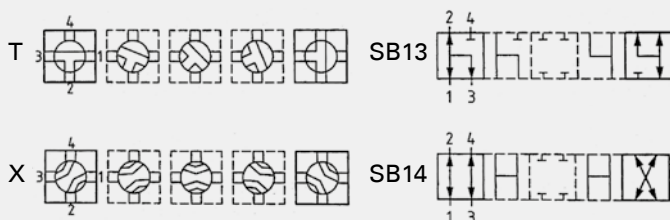

Further porting patterns page 262 to 267

### FLOW CHARACTERISTICS MPKH-X/T

