

Locking device for KH series \geq DN65 Steel

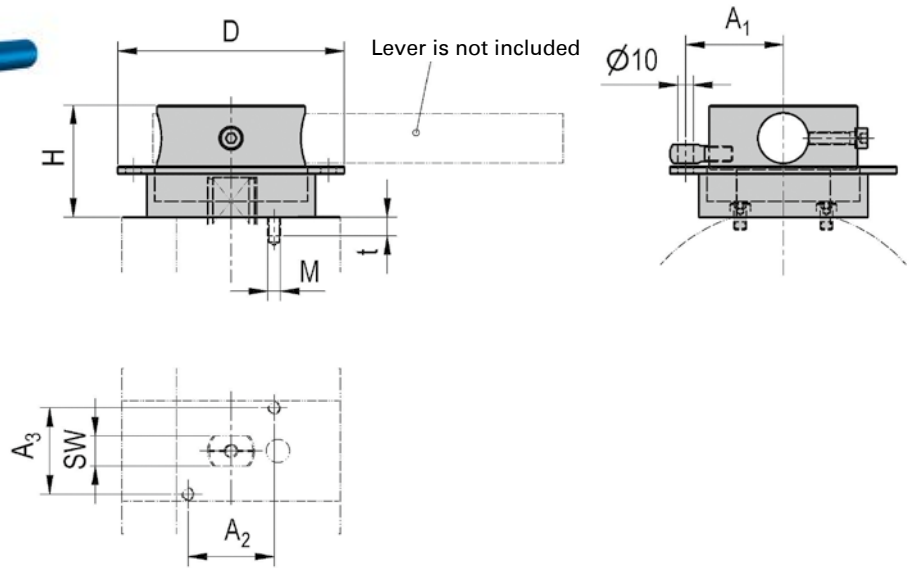

- Attention: Locking device requires modification at valve body
- Not suitable as retrofit

DIMENSIONS									ORDER CODE PER MATERIAL	
Type	SW	D	H	A ₁	A ₂	A ₃	M	t	Steel	
KH-DN65	16	145	71,5	62,5	55,15	55,15	M6	10	29509	
KH-DN80	19	145	71,5	62,5	55,15	55,15	M8	12	14590	
KH-DN100	24	155	74,5	67,5	62,23	62,23	M8	12	17665	
KH-DN125	36	165	104,5	72,5	69,3	69,3	M8	12	54677	

ORDER EXAMPLE

Mounting set consisting of adapter, bushing, fixing screws and eye bolt:

order text	article no.
Locking device for ball valve DN 65	29509

Assembled with ball valves:

ball valve type (ball valve design: see data sheets)	article no.	description
KH-DN65-SAE210-282A	- 32104 -	with locking device

MOUNTING SETS ARE VALID FOR

Type	KH-SAE	KH-ISO	KH-CETOP	KH-AS
Page	64 - 69	76 - 83	84 - 85	86 - 87